

CJ-317: 2 round basins wall mounted type drinking fountain with ventilation holes.

CJ-317 photo:

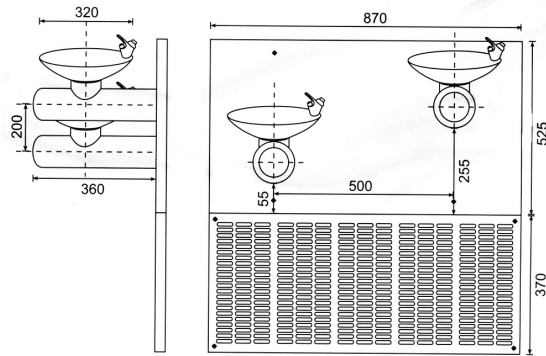

CJ-317 dimension:



Product characteristics:

- Unique design for drinking fountain in public place.
- All the structures and panels are made by stainless steel, which are durable and never rusty.
- The standard bubblers are top-press bubblers. But you can choose to change to front-press bubblers (The push buttons of the bubblers are on the front.).
- CJ-317 can be connected with CJ-318 (cooling system) to offer cold water. The cooling system can be put nearby CJ-317.